



TECHNICAL MANUAL

VERSION 16

8: EXTERNAL WINDOWS AND DOORS

8.

External Windows and Doors

Contents

Functional Requirements

- 8.1 General Requirements
- 8.2 Additional Requirements for External UPVC Window and Door Frames
- 8.3 Additional Requirements for External Timber Window and Door Frames
- 8.4 Additional Requirements for External Aluminium and Steel Window and Door Frames
- 8.5 Additional Requirements for Vertically Stacked Coupled Window Assemblies
- 8.6 External Bi-fold Doors

Limitations of Functional Requirements

1. These Functional Requirements do not and will not apply to create any Policy liability for any remedial works carried out by the Contractor or otherwise, nor to any materials used in those remedial works.
2. The guidance provided in this Section, is guidance that provides a suggested solution to meeting the Functional Requirements. If an alternative solution is selected, then this must still meet the Functional Requirements.
3. Means of escape, passive and active systems are not covered by the Warranty.
4. Indoor air quality is concerned with pollutants or moisture that may affect the health and safety of occupants by humidity, dust, odours or a reduction in oxygen. The occurrence of high indoor temperatures, and the measures to mitigate or control, are a health and welfare matter that is outside the scope of our Warranty that will need agreement with your Building Control provider.

Workmanship

1. Adequate testing and certification is required for any curtain wall and rain screen construction systems.
2. All workmanship must be within the tolerance requirements set out in this Technical Manual.
3. All work is to be carried out by a technically competent person in a workmanlike manner.

Materials

1. All materials should be stored, installed and protected correctly in a manner that will not cause damage or deterioration of the product.
2. All materials, products and building systems shall be appropriately tested and approved for their intended purpose.
3. All load bearing structural elements providing support to the Home will have a service life of not less than 60 years, unless specifically agreed otherwise with us. All other parts of the Home will have a lesser durability and need planned maintenance, repair or replacement during that reduced period.
4. Whilst there is and can be no Policy responsibility and/or liability for any roof covering, window/ door or 'decorative external cladding' (i.e. cladding which is decorative only and the substrate wall provides the main weather proof barrier) to achieve a performance service life of 60 years or less, such elements shall be designed and constructed so they have an intended service life of not less than where stipulated within this Manual.
5. Timber should be adequately treated or finished to resist insect attacks and be suitable for the position used within the structure. All timber treatment should be in accordance with relevant British Standards and Codes of Practice.
6. Timber used in the building to provide support to the structure must be appropriately seasoned to prevent excessive shrinkage and movement.
7. All materials should be suitable for the relative exposure of the building in accordance with the relevant British Standards.
8. Reclaimed materials may only be reused with the prior agreement with the Warranty Surveyor. Independent certification and/or testing of the suitability may be required.

Design

1. External window and doors frames, and roof lights shall be designed and constructed so that they:
 - a. Meet the requirements of BS 6375-1 are durable and resistant to weather;
 - b. Have adequate thermal performance and air tightness;
 - c. Have sufficient strength to withstand operational and wind loads;
 - d. Offer reasonable resistance to unauthorized entry;
 - e. Can be operated readily and safely by the user.
2. Windows and roof lights shall be designed and constructed so that they offer, where necessary, sufficient natural ventilation.
3. External principal entrance doors and frames shall be designed and constructed so that they permit convenient access for users.
4. The following additional elements shall be supported by structural calculations designed by an Engineer:
 - a. Structural elements outside the parameters of Building Regulations.
 - b. Specialist structural works.
 - c. Reinforced concrete elements.
 - d. Precast structural elements.
 - e. Any engineered beams/posts manufactured off-site.
5. Damp proofing works should prevent any external moisture passing into the internal environment of the building.
6. Projects consisting of non-standard/modern methods of construction must be supported with evidence of valid independent third party product conformity certification before an offer of Warranty is provided. These types of constructions must be declared before commencement.

8.

**External
Windows
and Doors**

8.1 General Requirements

Provision of information

A full set of design drawings and specifications shall be made available to the Warranty Provider and all other interested parties prior to the associated works starting on site. This may include:

1. Evidence that the external windows and doors are suitable for the site exposure. e.g. A manufacturer's declaration of performance for the site.
2. Evidence of certification confirming weather-tightness rating as detailed within BS 6375.
3. Evidence of UKCA marking in accordance with UK Construction Production Regulation.
4. Details of external window and door fixing will be required.
5. Details of sealing around the frame will need to be confirmed.

The Warranty Surveyor, at their discretion, may also request supporting information that demonstrates suitability for use of any materials or systems contained within the above.

Introduction

Workmanship should follow the recommendations of BS 8213-4.

Factory made and bespoke external windows and doors should be selected to withstand the design weather conditions and be classified and tested in accordance with the following weather performance standards:

- BS 6375-1 Weather tightness.
- Air permeability - BS EN 12207 - Classification & BS EN 1026 - Test method.
- Water resistance - BS EN 12208 - Classification & BS EN 1027 - Test method.
- Wind resistance - BS EN 12210 - Classification & BS EN 12211 - Test method.

For developments that are 6 storeys and above, the test pressure should be at least 25% of the design wind load for weathertightness. For further information, advice should be sought from our Major Projects Team.

Additional requirements of CWCT Technical Note 95 also apply for developments that are 6 storeys and above.

External bay, oriel and dormer windows require particular care in detailing and fitting so that they are stable, weather tight and reasonably air tight.

Roof lights should be proprietary components, fixed within prepared openings in accordance with the manufacturer's instructions and have effective weather sealing.

Non-timber components should comply with the following British Standards (as appropriate), and be installed and fixed in accordance with the manufacturer's recommendations:

- BS EN 514 Plastics. Poly(vinyl chloride) (PVC) based profiles. Determination of the strength of welded corners and T-joints.
- BS 7412 Specification for windows and doorsets made from unplasticized polyvinyl chloride (PVC-U) extruded hollow profiles.

External UPVC windows and doorsets should be designed and constructed in accordance with the requirements of the following British Standards:

- BS 6262 Code of Practice for glazing for building.
- BS 6375: 1 Performance of windows.
- BS 7412 Specification for windows and doorsets made from unplasticized polyvinyl chloride (PVC-U) extruded hollow profiles.
- BS 8213 Windows, doors and roof lights.

External windows and doors should comply with the current Building Regulations taking into consideration:

- Thermal insulation.
- Ventilation.
- Safety.
- Security.

Draught Seals

External doors and opening lights to windows should be reasonably air tight by ensuring that effective draught seals are fitted.

Control of Condensation

External window and door installations must be constructed to ensure resistance to the effects of condensation forming on the surface of the frames, the glazing and at junctions with the surrounding building fabric.

To ensure that condensation does not occur and give rise to mould growth in these areas, external windows and doors must be:

- Thermally efficient to the level identified within the guidance of the relevant Building Regulations.
- Detailed and constructed to ensure continuity of insulation and avoidance of thermal bridges at lintels, sills and jambs.
- Detailed to be contributing to the requirements of airtightness, providing appropriate seals between frame sections, opening lights and at junctions with surrounding fabric e.g. housing window boards into frames to prevent the opportunity for air leakage.

Security

The design and specification of external doors and windows which provide access into a dwelling or into a building containing a dwelling should take into account the requirements of current relevant Building Regulations to ensure the system is classified and tested to the appropriate burglar resistance class.

In addition:

- The frames of secure external doorsets and windows should be mechanically fixed to the building structure in accordance with the manufacturer's tested specifications.
- Where an external doorset is installed in a lightweight framed wall, a resilient layer should be incorporated to reduce the risk of anyone breaking through the wall to access the locking systems. The resilient layer should be for the full height of the door and 600mm either side of the doorset, 9mm timber sheathing or expanded metal may be used.
- Any glazing which if broken in an attempt to gain access to the locking device on a door must be a minimum class of P1A in accordance with BS EN 356:2000.
- A means of caller identification should be provided at the main door to the dwelling to allow means of seeing callers. The same external doorsets should also have a securely fixed door chain or door limiter fitted.
- The external doors and windows should be manufactured to a design that has been shown by tests to meet the security requirements of PAS 24.

External windows and doors installation

External windows and door frames should be installed so that:

- They do not carry loads unless designed to do so.
- They are plumb and square and they satisfy the 'Tolerances' section of this Technical Manual.
- External doors and opening lights to windows should be reasonably air tight by ensuring that effective draught seals are fitted.
- The masonry on the external side of vertical DPC should not be in contact with internal finishes.
- The window head is set back behind the edge of the cavity tray.
- The frame to wall junction is weather tight and reasonably air tight.
- Where checked rebated reveals are provided, the frame should be set back behind the outer leaf and should overlap it. In other areas of exposure, the frame should be set back at least 38mm and overlap the DPC.
- Distortions of doors should be minimized by not locating radiators or other

heaters close to doors.

- The reveal should be protected throughout its width by a continuous DPC. The width of the DPC should be sufficient to overlap/be fixed to the frame and fully protect the reveal. Alternatively, an insulated finned cavity closer with third-party certification may be used.
- Proprietary materials with third party certification should be used to close cavities at window and door openings. They should also be installed in accordance with the manufacturer's recommendations.

Check (rebated) reveals

Check (rebated) reveals will be required in the following locations:

- Scotland
- Northern Ireland
- Areas of very severe exposure in England & Wales

Installations into check reveal apertures need to consider the following:

- Frame to be positioned centrally behind the external skin with a minimum overlap of frame behind the external skin of 12mm on both sides.
- Where applicable the frame should be positioned vertically with the head of the frame positioned behind the external wall at the head.
- Vertical DPC within the check should be positioned as far forward as possible, with the vertical DPC between the rear of the external skin and the external face of the frame.

Additional requirements for coastal locations

Where developments are within a coastal location additional Warranty requirements should be met.

For the purpose of this Technical Manual we are considering sites within 5km inland from the shore line or sites located in 'tidal' estuarine areas where they are within 5km of the general shoreline.

Further information on Warranty requirements within a coastal location can be found in 'Appendix B - Coastal Locations'.

Protection for falling

For houses and flats the guidance in Approved Document K2 (Building Regulations England and Wales) specifies a minimum guard height of 800mm to external window openings in the external wall. This would normally be achieved by forming external window openings of at least 800mm above the finished floor level. The wall beneath the opening is therefore considered to be the barrier to falling.

Where external window openings are formed less than 800mm from the finished floor level, permanent guarding should be provided to the opening in accordance with the design requirements specified in the relevant Building Regulations.

If external window openings are formed less than 800mm from the finished floor level, and there is no permanent guarding provided, and the glass is required to act as the barrier and provide containment to persons falling against it; the glass needs to be designed in accordance with the requirements of BS 6180. The designer shall determine the potential impact energy by establishing the perpendicular unhindered distance that could be travelled prior to impact.

In the absence of an assessment by a suitably qualified person, any glass which is required to provide containment must meet with BS EN 12600 Class 1(C)1.

Critical locations

Glazing in doors and windows in areas known as 'critical locations' needs to be given special consideration in order to prevent potential injury to people within or around the building.

These 'critical locations' are:

- In a door or in a side panel adjacent to a door where the glazing is within 300mm of the door and the glazing is situated between floor level and a height of 1500mm.
- In an internal or external wall or partition between floor level and a height of 800mm.

It is important that any glazing within these 'critical locations' should be either:

- Provided with permanent protection.
- Small panes.
- Robust.
- Break safely.

Glazing to critical locations - doors and side panels

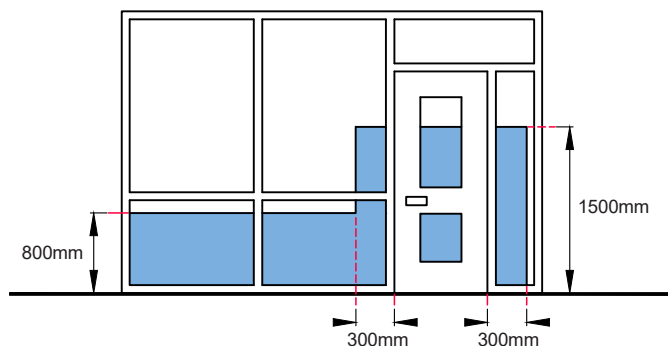

Glazing to critical locations - windows

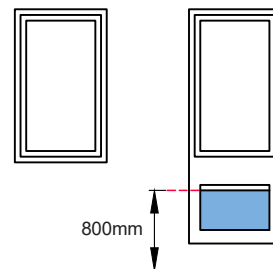

If permanent protection is provided in the form of fixed guarding, there is no requirement for the glazing itself to be of a special type. Permanent protection may take the form of railing or barriers and should:

- Be designed to be robust.
- Have a maximum opening or gap in any railing of 75mm or less.
- Be a minimum of 800mm high.
- Be non-climbable (especially where floor is acting as a balcony).

Small panes, either an isolated pane within glazing bars or copper or lead lights should be restricted in size so that any breakage would be strictly limited.

Small panes should be:

- No more than 0.5m² in area.
- No wider than 250mm.

Where annealed glass is used a minimum of 6mm thickness is recommended (4mm for copper or lead lights). Some materials are inherently strong such as glass blocks or polycarbonate, whereas annealed glass will need to be of an increased thickness as the area of the panel increases to be considered 'safe'. As an alternative to any of the above solutions it is possible for the material to break 'safely' when tested to BS EN 12600 which would mean that:

- Only a small opening was created with a limited size of detached particles.
- The balance would create only small pieces that are not sharp or pointed.
- The pane disintegrates with only small detached particles.

A glazing material would be suitable for a critical location if it meets the requirements of BS 6262 - 4 Table 1 when tested in accordance with BS EN 12600. Glass installed in a door or in a side panel to a door that exceeds 900mm wide must meet the relevant requirements of BS EN 12600 and BS 6262 - 4.

Glazing to critical locations

Glazing should be in accordance with BS 6262. Insulated glass units (IGU) should meet requirements of BS EN 1279 - Glass in building - insulating glass units, be CE marked and carry third-party accreditation.

- They should have continuous dual seals; single seal units are not acceptable.
- Desiccant should be provided to spacer bars.
- Any glazing on-site must have a drained and ventilated bottom bead with a minimum gap of 5mm between the edge seal of the insulated glass unit and the bottom channel of the frames glazing rebate.
- Any glazing with an area greater than 1m² must have a drained and ventilated bottom bead with a minimum gap of 5mm between the edge seal of the insulated glass unit and the bottom channel of the frames glazing rebate.
- Glazing with an area less than 1m² may be solid bedded.
- UPVC frames and spacer bars should be stamped with BS 7412, 7413 and 7414.

Linseed oil glazing putty should not be used when the joinery is finished with vapour permeable paint or stain. Glazing putty should also not be used with organic solvent-based stains, the putty should be neatly finished to receive a protective paint coat.

Putty is not suitable for laminated glass and double-glazed units, the workmanship

should be in accordance with BS 8000: 7. To ensure the compatibility of the whole glazing system is to a high level of workmanship and control, it is recommended that factory pre-glazed systems be installed in all external openings.

The window beads should suitably lap the external windows and doors to prevent premature degradation of the glazing unit.

External glazing beads should be pinned at a maximum of 150mm centres (a maximum of 50mm from corners) or screwed at 200mm centres (maximum 50mm from corners).

The preferred method of installation for double-glazed units is either:

- Drained and ventilated frames, as recommended by the Glass and Glazing Federation (GGF), where possible this method should be adopted for external glazing.
- Solid bedding of units in 16mm-18mm deep frame rebates; 18mm rebates are recommended by the GGF to allow for tolerances. In all cases, sealants should not be sensitive to ultraviolet light. External glazing beads should be fixed at a maximum of 150mm centres, and the glazing bedded in non-setting putty. Louvre windows should not be used and double-glazing should be fixed and bedded as recommended by the GGF.

Appearance of glazing

Glass must meet the visual assessment criteria of the Glass and Glazing Federation and CWCT Technical Note 35 (TN 35). The total number of faults permitted in a glass unit shall be the sum total of those permitted by the relevant BS EN Standard for each pane of glass incorporated into the unit concerned.

Acceptable faults include:

- Inclusions, bubbles, spots and stains.
- Residues within the insulated glass unit cavity.
- Fine scratches not more than 25mm long.
- Minute particles.

When assessing the appearance of glass:

- The viewing distance used shall be the furthest stated in any of the BS EN Standards for the glass types incorporated in the glazed unit. In the event of doubt the viewing distance shall be three metres.
- The viewing shall commence at the viewing distance and shall not be preceded by viewing at a closer distance.
- The viewing shall be undertaken in normal daylight conditions without use of magnification.

The above does not apply within 6mm of the edge of the pane, where minor scratching is acceptable. Scratches on external doors, windows and frames and factory finished door and window components should not have conspicuous abrasions, or scratches when viewed from a distance of 0.5m.

- Surface abrasions caused during the building-in process should be removed in accordance with the manufacturer's instructions, which may include polishing out, re-spraying or painting.
- In rooms where there is no daylight, scratches should be viewed in artificial diffused light from fixed wall or ceiling outlets and not from portable equipment.

Nickel sulphide inclusions in glazing

In low-rise buildings which exceed three storeys in height, 100% of the toughened glazing used from the third storey upwards must be heat soak tested in accordance with BS EN 14179-1. The glass must be permanently marked in accordance with BS EN 14179-1 and substantiated evidence of heat soak testing must be disclosed for all effected panes.

Alternatively where toughened glazing does not exceed 50kg in weight and where there is safe and easy access to remove and replace the glazing without the need for access scaffolding or fall arrest equipment, a methodology statement of how this will be undertaken should be provided.

Please note: A storey is defined as the space between two consecutive floors or a floor and a roof. The number of storeys should be counted from the lowest external ground level.

Gaps around external windows and doors

Gaps around external windows and doors should be sized to allow for thermal movement and this will vary depending on the material of the frame.

Material	Recommended gap per side for width of structural openings (mm)		
	Less than 1.5m*	1.5m – 3.0m*	3.0 – 4.5m**
Upvc-white	5	5	7.5
Upvc-non-white	7.5	7.5	11
Timber	5	5	5
Steel	4	5	6
Aluminium	5	5	7.5

Notes:

* The maximum gap permitted for openings less than 3m should be 10mm.

** For openings more than 3m, the maximum gap permitted should be 15mm.

For gaps greater than 5mm, a backing strip should be provided behind the sealant and the sealant should have a minimum depth of 6mm.

External window and door frames should be installed in accordance with the manufacturer's instructions.

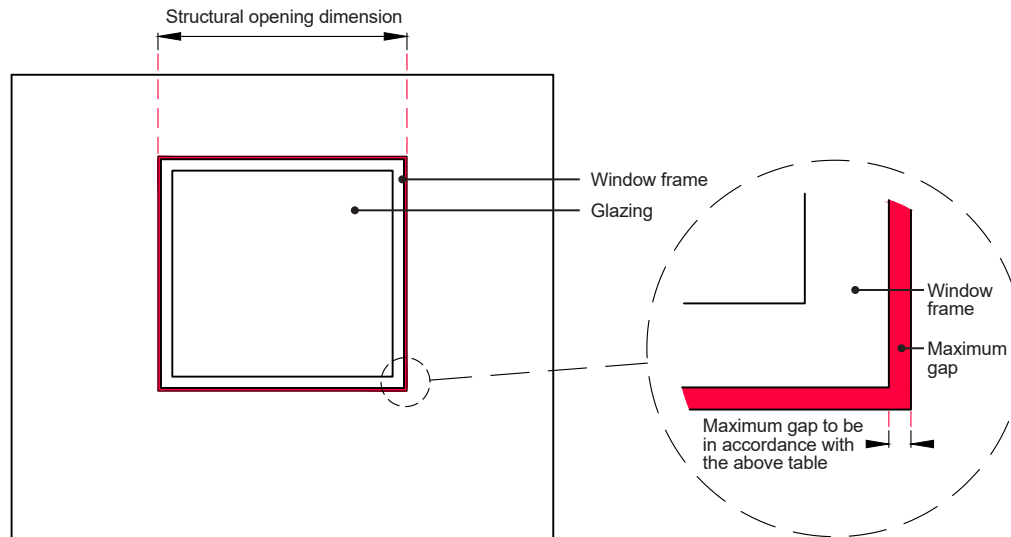

Sealants

Thermally insulating filling materials should be applied to the perimeter gap around the frames (such as PU foam, or impregnated tapes). Perimeter joints needs to be continuously sealed on both the outside and the inside of the frames. Sealants should be appropriate to:

- The frame surface.
- The substrate material.
- Joint size and configuration.
- Anticipated joint movement.
- Anticipated weather exposure conditions.

Wet sealants (e.g. silicones) should be tested and classified in accordance with BS EN ISO 11600.

When using impregnated tapes, over-capping with a wet sealant is generally not required – manufacturer's instructions should be followed.

In situations where the sealant will rely on atmospheric moisture to begin curing then deep filling should be avoided.

When applying sealant:

- Apply against a firm backing, forcing it against the sides of the joint.
- It should not be applied to the backing as this restricts lateral movement of the joint.
- Any gaps greater than 6mm require a closed-cell oversized polyethylene (PE) foam backing rod be included.
- A width to depth ratio of between 1:1 and 2:1 should be observed.
- When applying a fillet joint a minimum 6mm contact to non-porous, and 10mm to porous substrates should be achieved.
- Seal should be provided between any sill and frame.

For further guidance on the application on sealants around external windows and doors, please see BS 8213-4 Code of practice for the survey and installation of windows and external doorsets.

Finishing trims

The use of proprietary surface fixed finishing trims e.g. D-moulds, should be undertaken only as part of a designed junction between window and door framing and the surrounding opening.

For this purpose, surface finishing trims:

- Must be compatible with the materials used within the frame.
- Must be robust in their attachment.
- Must not be detrimental to the performance of the junction e.g. create thermal bridging.
- Must not impede the function or operation of the window or any attached fitments e.g. obstructing trickle vents, framing drainage outlet.

The inclusion of finishing trims should not be considered as a means to:

- Achieve weather tightness, unless they are included within appropriate weather and water tightness testing conducted on the window and door system.

Extend frame dimensions where windows are undersized for the opening. Only recognised sections that form part of the window system can be used for this purpose e.g. proprietary or manufactured interlocking sections ('knockons'), or manufacturer led alterations using fixed sections (adhesively bonded planted sections).

These illustrations show accepted practice for forming weather resistant openings and may not indicate the full extent of insulation requirements to meet relevant Building Regulations.

Typical vertical section through an external window head

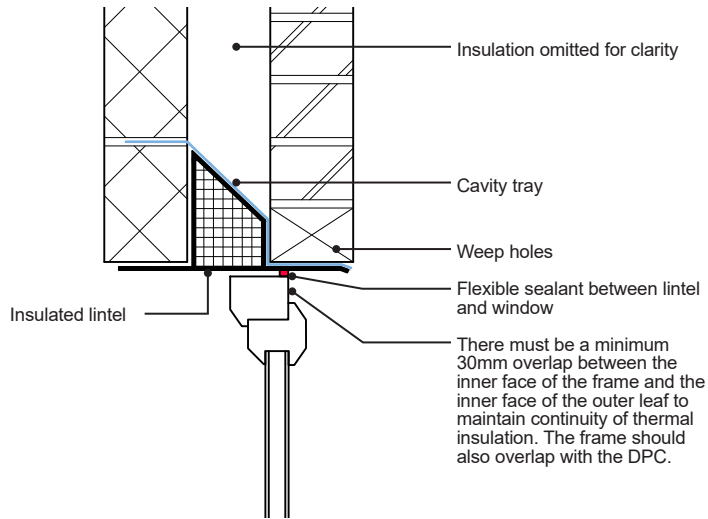

Typical vertical section through an external window sill

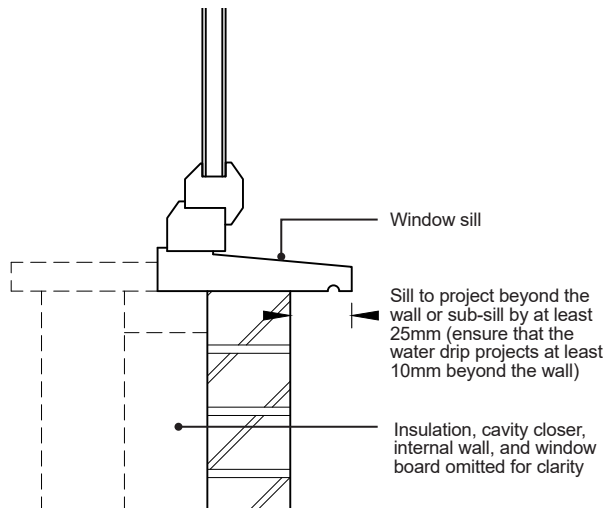

Typical external window reveal (normal exposure)

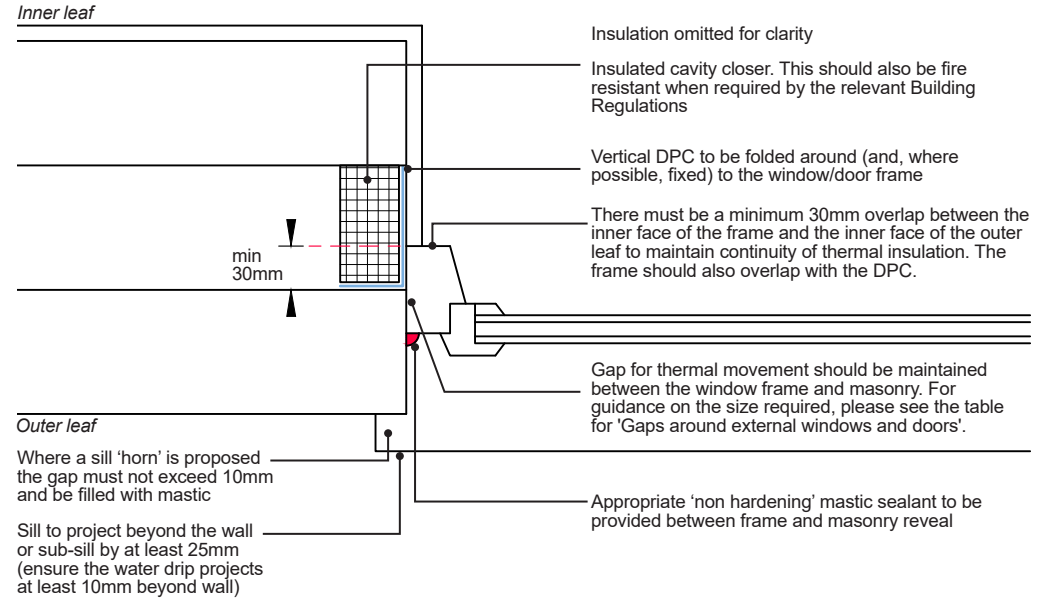

Checked rebate window frame detail

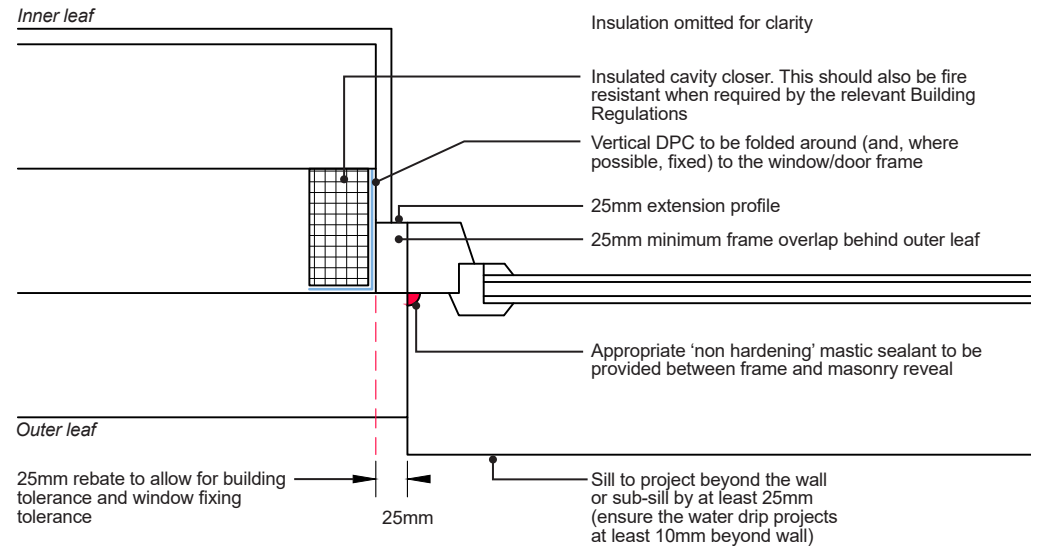

When installing window/door frames in a checked rebate, allow for the frame to be deeper:

- To accommodate the 25mm rebate, and,
- To allow for opening lights to open clear of the masonry/render.

Level access

*see Building Regulations for disabled ramp design and landing dimensions.

The construction of the access landings and ramps must not compromise the DPC in the walls

Landing should be laid to a 1:60 fall in a single direction away from door

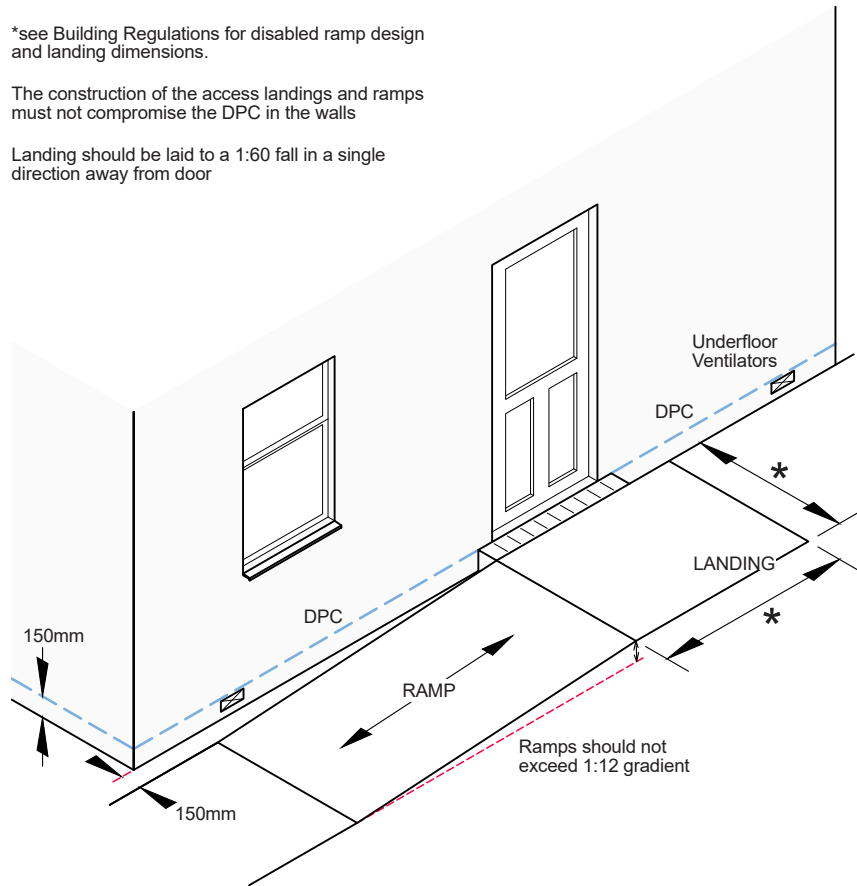

Level thresholds

Thresholds and sills should be at least 150mm above finished ground level. However, where a level (threshold) access is required, the general guidance in this section should be followed - ensuring a high level of supervision and workmanship together with the correct specification of materials and consideration to design, location, and exposure.

Wherever possible, locate the entrance door away from the prevailing weather and provide a storm porch. Where a drainage channel is provided, this must be connected to the storm drainage system to prevent flooding occurring and water ingress into the building.

It is recommended that a mat well be constructed within the entrance hall to accommodate the swing of the door without fouling the carpet and/or the proprietary door seal.

Level thresholds in timber frame superstructure

At the level threshold open perpend should be provided in close proximity to the timbers on each side of the door opening one brick course below the lowest timber. The open perpend must provide adequate ventilation of the external wall cavity, and drainage to disperse water that may penetrate the cladding.

Typical level threshold where a porch/canopy is provided

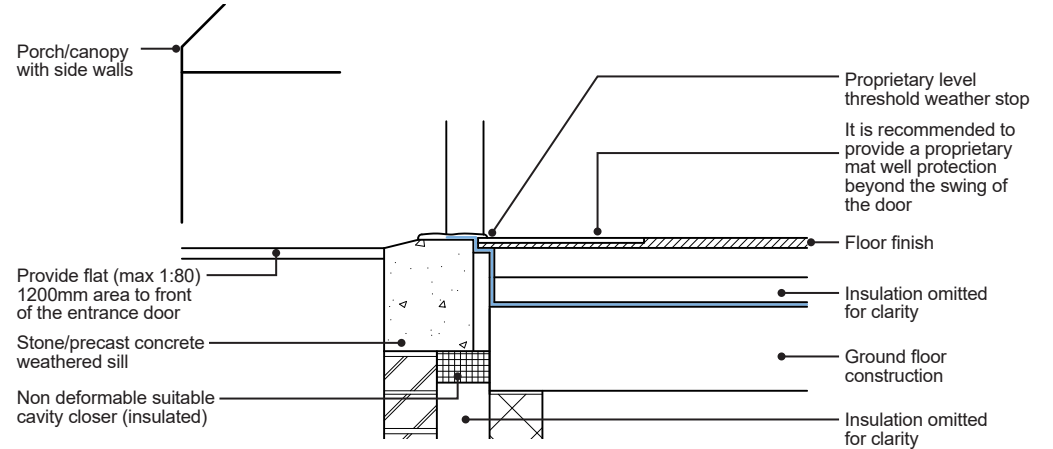

Typical level threshold without canopy protection

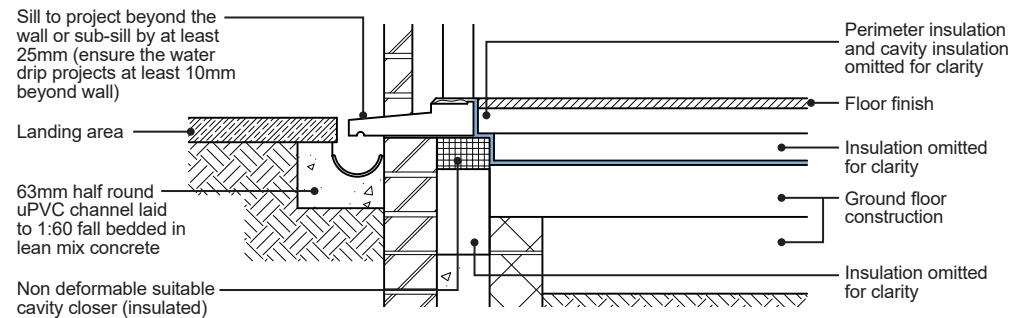

Timber sill

Where timber sills are installed, to prevent deterioration of the timber due to the risk of moisture ingress, a drained and vented void must be provided immediately in front of the sill (at least 125mm invert).

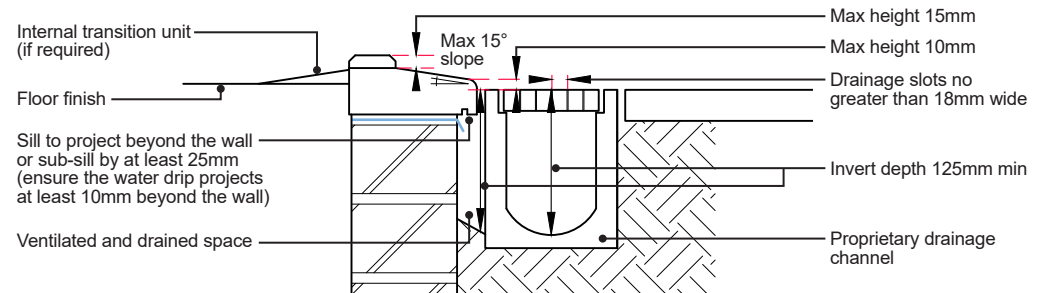

These illustrations show accepted practice for forming a weather resistant threshold detail and may not indicate the full extent of insulation requirements to meet relevant Building Regulations.

8.

External Windows and Doors

8.2

Additional Requirements for External UPVC Window and Door Frames

Provision of information

A full set of design drawings and specifications shall be made available to the Warranty Provider and all other interested parties prior to the associated works starting on site. This may include:

1. Evidence that the external windows and doors are suitable for the site exposure. e.g. A manufacturer's declaration of performance for the site.
2. Evidence of certification confirming weather-tightness rating as detailed within BS 6375.
3. Evidence of UKCA marking in accordance with UK Construction Production Regulation.
4. Details of external window and door fixings will be required.
5. Details of sealing around the frame will need to be confirmed.

The Warranty Surveyor, at their discretion, may also request supporting information that demonstrates suitability for use of any materials or systems contained within the above.

Certification

External uPVC windows and doors shall have evidence of certification confirming weather-tightness rating as detailed within BS 6375.

The design and construction of factory assembled external windows must meet BS 7412.

Non factory assembled units and 'bespoke' units are also expected to meet the same standard.

Fixings for external uPVC windows and doorsets

Frames should be fixed in accordance with the manufacturers recommendations or, if no instructions are given, with the following guidance:

Fixing locations for external uPVC windows and doors

Wherever practicable, all four sides of the frame should be secured as follows:

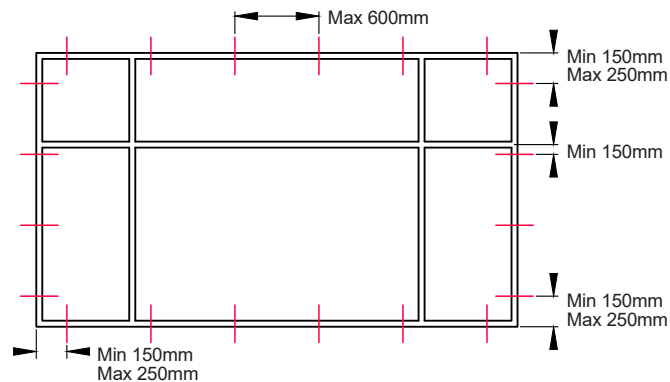

- Corner fixings should be between 150mm and 250mm from the external corner.
- No fixings should be less than 150mm from the centre line of a mullion or transom.
- There should be a minimum of two fixings on each jamb and sill, with intermediate fixings at centres no greater than 600mm.
- If the head is fixed with polyurethane foam, then the fixings at the head may be as follows:
 - a) Frame width up to 1200mm - no fixings;
 - b) Frame width 1201mm to 2400mm - one central fixing;
 - c) Frame width 2401mm to 3600mm - two equally spaced fixings.

Note: These fixings do not apply to French doors, patio doors, or bi-fold doors. Manufacturers recommended fixing details should be followed.

Fixing type

- Two methods of fixing are lug fixing, or through frame fixing. These can be used separately or as a combination.
- Should be galvanised steel cramps or by non-corrodible screw fixings appropriate to the surrounding wall.

Fixing substrate penetration

Fixings should penetrate surrounding structure as per the following:

- Into masonry, by at least:
- 40mm for external windows.
 - 50mm for external doors.

Into structural timber framing, by at least:

- 25mm for all situations.

For fixings into surrounding structure formed by steelwork which is a maximum of 2mm thick should be made with:

- Power driven hardened self-drilling screws or self-tapping screws (with pilot hole).

For fixings into surrounding structure formed by steelwork which is greater than 2mm thick should be made:

- Either into pre-tapped holes with machine screws a minimum of 5mm diameter or with power driven hardened self-drilling screws.

Notes:

- Please refer to the lintel manufacturers' recommendations for making mechanical fixings to the underside of the lintel.
- Fixings should not be made into the insulated cavity closer.

Gaps around external windows and doors

Gaps around external windows and doors should be sized to allow for thermal movement and this will vary depending on the material of the frame.

Material	Recommended gap per side for width of structural openings (mm)		
	Less than 1.5m*	1.5m – 3.0m*	3.0 – 4.5m**
Upvc-white	5	5	7.5
Upvc-non-white	7.5	7.5	11

Notes:

* The maximum gap permitted for openings less than 3m should be 10mm.

** For openings more than 3m, the maximum gap permitted should be 15mm.

For gaps greater than 5mm, a backing strip should be provided behind the sealant and the sealant should have a minimum depth of 6mm.

External window and door frames should be installed in accordance with the manufacturer's instructions.

Glazing

The glazing installation should follow manufacturer's guidance.

In order to achieve acceptable performance, any glazing on-site must:

- Have a drained and ventilated bottom bead, with a minimum gap of 5mm between the edge seal of the insulated glass unit and the bottom channel frames glazing rebate.
- Have window beads that suitably lap the external windows and doors to prevent premature degradation of the glazing unit.

Standards

Design, Specification, and Manufacturing

- BS EN 514 Plastics. Polyvinyl chloride (PVC) based profiles. Determination of the strength of welded corners and T-joints.
- BS 7412 Specification for windows and doorsets made from unplasticized polyvinyl chloride (PVC-U) extruded hollow profiles.
- BS 6262 Glazing for buildings - Code of practice for safety related to human impact.
- BS 6375 Performance of windows and doors - Classification for weathertightness and guidance on selection and specification.
- Air permeability - BS EN 12207 - Classification & BS EN 1026 - Test method.
- Water resistance - BS EN 12208 - Classification & BS EN 1027 - Test method.
- Wind resistance - BS EN 12210 - Classification & BS EN 12211 - Test method.
- BS EN 1670 Building hardware. Corrosion resistance. Requirements and test methods.

Installation

- BS 8213 Windows and doors - Code of practice for the survey and installation of windows and external doorset.
- BS 8000: 7 Workmanship on building sites. Code of Practice for glazing.

8.

External Windows and Doors

8.3

Additional Requirements for External Timber Window and Door Frames

Provision of information

A full set of design drawings and specifications shall be made available to the Warranty Provider and all other interested parties prior to the associated works starting on site. This may include:

1. Timber and other wood based materials need to comply with the relevant requirements of BS EN 942. Evidence of this needs to be provided to the Warranty Surveyor.
2. Evidence that the external windows and doors are suitable for the site exposure. e.g. A manufacturer's declaration of performance for the site.
3. Evidence of certification confirming weather-tightness rating as detailed within BS 6375. External bespoke timber windows and doors that cannot provide a BS 6375 rating will need to be water tested as per CWCT Note 41.
4. Evidence of UKCA marking in accordance with UK Construction Production Regulation.
5. Details of external window and door fixing will be required.
6. Details of sealing around the frame will need to be confirmed.
7. External bespoke timber windows and doors must provide a detailed specification of the design, construction, and durability of the proposed units. Bespoke timber windows will not be acceptable for use without prior approval from the Warranty Surveyor.

The Warranty surveyor, at their discretion, may also request supporting information that demonstrates suitability for use of any materials or systems contained within the above.

Timber frame quality

Workmanship should follow the recommendations of BS 1186: 2. The design and construction of factory assembled external windows must meet BS 644:2009.

Non factory assembled units and 'bespoke' units are also expected to meet the same standard.

Timber used for external joinery should be a species classified as suitable in BS EN 942 and preservative treated; if not, use a moderately durable species or better (sapwood excluded). Guidance on selection is provided in TRADA Wood Information Sheets 3.10 and 4.16.

External joinery should be designed and constructed in accordance with the requirements of the following British Standards:

- BS 4787: 1 Internal and external wood door sets, door leaves and frames.
- BS 6262 Code of Practice for glazing for buildings.
- BS 6375: 1 Performance of windows.
- BS 644: 1 Wood windows.
- BS 8213: 1 Windows, doors and roof lights.

Fixings for external timber windows and doorsets

Frames should be fixed in accordance with the manufacturer's recommendations, or if no instructions are given, with the following guidance.

Fixing locations for external timber windows and doorsets

Wherever practicable, all four sides of the frame should be secured as follows:

*Additional fixing for windows & doorsets over 1800mm wide

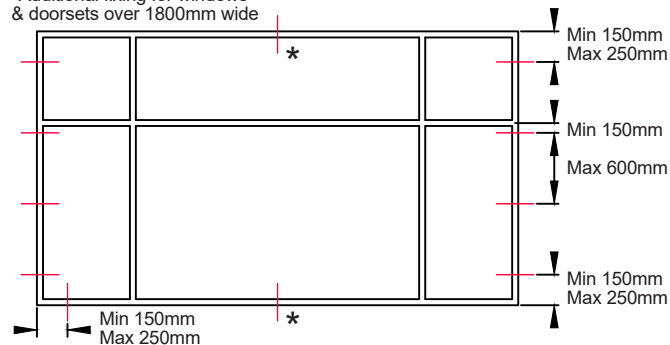

- Corner jamb fixings should be between 150mm and 250mm from the external corner.
- Intermediate fixings should be at centres no greater than 600mm.
- There should be a minimum of two fixings on each jamb.
- On external windows and doorsets over 1800mm wide, central head and sub-sill fixings should be provided.

Fixing type

- Two methods of fixing are lug fixing, or through frame fixing. These can be used separately or as a combination.
- Should be galvanised steel cramps or by non-corrodible screw fixings appropriate to the surrounding wall.

Fixing substrate penetration

Fixings should penetrate surrounding structure in line with the relevant section below.

Into masonry, by at least:

- 40mm for external windows.
- 50mm for external doors.

Into structural timber framing, by at least:

- 25mm for all situations.

For fixings into surrounding structure formed by steelwork which is a maximum of 2mm thick should be made with:

- Power driven hardened self-drilling screws or self-tapping screws (with pilot hole).

For fixings into surrounding structure formed by steelwork which is greater than 2mm thick should be made:

- Either into pre-tapped holes with machine screws a minimum of 5mm diameter or with power driven hardened self-drilling screws.

Note: Fixings should not be made into the insulated cavity closer.

Gaps around external windows and doors

Gaps around external windows and doors should be sized to allow for thermal movement and this will vary depending on the material of the frame.

Material	Recommended gap per side for width of structural openings (mm)		
	Less than 1.5m*	1.5m – 3.0m*	3.0 – 4.5m**
Timber	5	5	5

Notes:

* The maximum gap permitted for openings less than 3m should be 10mm.

** For openings more than 3m, the maximum gap permitted should be 15mm.

For gaps greater than 5mm, a backing strip should be provided behind the sealant and the sealant should have a minimum depth of 6mm.

External window and door frames should be installed in accordance with the manufacturer's instructions.

Glazing

Glazing should be installed as per the manufacturer's guidance and any relevant standards.

In order to achieve acceptable performance, any glazing on-site must:

- Have a drained and ventilated bottom bead, with a minimum gap of 5mm between the edge seal of the insulated glass unit and the bottom glazing rebate.
- Have window beads that suitably lap the external windows and doors to prevent premature degradation of the glazing unit. Glazing spacer bars must not project above the top of glazing beads and rebate where they can be affected by UV.
- Have the insulated glass unit set into position using location and setting blocks set at intervals around the perimeter of the insulated glass unit. The spaces in between allow for any penetrating moisture to run to the bottom rebate and out.

Where internally glazed windows are proposed, the design must facilitate drainage to the same levels as that of externally beaded windows.

Drained and ventilated systems are the preferred method for installation of insulated glass units. Various systems can be used to seal contact points between glazed unit faces and timber e.g. self-adhesive dry glazing tapes, extruded gaskets, butyl tapes/gaskets with sealant capping.

Importantly however mixing and matching approaches should be avoided.

Fully bedded insulated glass units installations should only be accepted where glazing operations are carried out within a factory controlled environment with appropriate QA procedures as the extensive monitoring of sealant use on site is very difficult to execute.

Glazing beads

Glazing should be installed as per the manufacturer's guidance and any relevant standards.

Glazing beads should:

- Not be mitred but scribed to bead profiles at junctions.
- Have a wider bottom bead running the full width of the opening and projecting beyond the face of the frame to conceal the drainage provision. The bottom bead should have a 1:6 (11° angle) weathering slope on its top surface.
- Have an uppermost horizontal glazing bead that runs the full width of the opening to protect the top of the jamb beads on either side.
- Have side (jamb) beads that stop short of the bottom bead by 3mm – where the bottom bead has a 1:6 (11° angle) weathering slope on its top surface, the gap can be reduced at the glass face by cutting the ends of the side beads to a shallower pitch.
- Be securely fixed with pins or screws at a 200mm maximum spacing, starting at 50mm from corners to create compression of seal provided between the timber sections and the glass surfaces.

On site operations that incorporate site applied capping sealant on drained and vented glazing systems should be executed in strict accordance with the design and specification.

Decoration, treatment and protection of external timber windows and doors

It is recommended that all external windows pre-finished to ensure all parts of external timber windows and doors, including joints, are fully protected during the build process. Where this is not the case, the external windows should be protected using appropriate weather resistant sheeting until paint finishes are applied.

Preservative-treated joinery cut or adjusted on-site should be brushed liberally with an appropriate and coloured preservative. Where the colour of the preservative will adversely affect the final appearance of the joinery, an appropriate clear preservative should be used.

Where a painted finish is proposed to the external window/door frame and opening units; the primer coat should be applied to all final exposed parts, including rebates prior to glazing installed or bottoms of external doors, or external windows.

The use of oak in external windows and doors

For the purpose of this section there are three types of oak considered;

- Green Oak - recently felled Oak with a moisture content typically between 60%-80%.
- Air Dried (seasoned) Oak - naturally stored Oak with a natural seasoning process moisture content up to 30%
- Certified kiln dried oak - processed seasoned timber with a moisture content of 12% or less.

Green or air dried Oak is not acceptable for use when manufacturing external windows and doors.

Certified kiln dried Oak with a certified moisture content of 12%, is acceptable for the manufacturing of windows and doors, subject to the external joinery meeting the relevant British Standards for manufacturing/testing, as outlined in this section.

Ground floor and timber sill typical detail

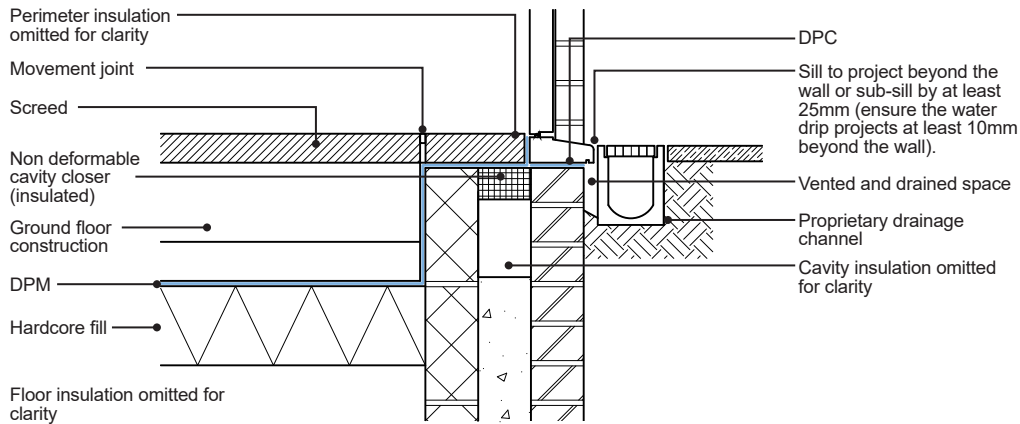

Timber sill

Where timber sills are installed, to prevent deterioration of the timber due to the risk of moisture ingress, a drained and vented void must be provided immediately in front of the sill (at least 125mm invert).

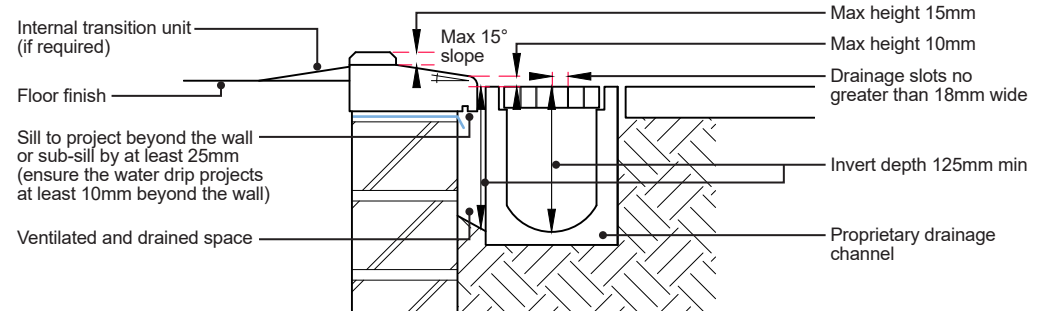

Standards

Design, Specification and Manufacturing

- BS 1186: 2 Timber for and workmanship in joinery - Specification for workmanship.
- BS 644 Timber windows and doorsets. Fully finished factory-assembled windows and doorsets of various types.
- BS 6375-1 Weather tightness.
- Air permeability - BS EN 12207 - Classification & BS EN 1026 - Test method.
- Water resistance - BS EN 12208 - Classification & BS EN 1027 - Test method.
- Wind resistance - BS EN 12210 - Classification & BS EN 12211 - Test method.
- BS 4787: 1 Internal and external wood door sets, door leaves and frames.
- BS 6262 Code of Practice for glazing for buildings.
- BS 8213: 1 Windows, doors and roof lights.
- BS 942 Timber in joinery. General requirements.

8.

External Windows and Doors

8.4

Additional Requirements for External Aluminium and Steel Window and Door Frames

Provision of information

A full set of design drawings and specifications shall be made available to the Warranty Provider and all other interested parties prior to the associated works starting on site. This may include:

1. Evidence that the external windows and doors are suitable for the site exposure. e.g. A manufacturers declaration of performance for the site.
2. Evidence of certification confirming weather-tightness rating as detailed within BS 6375.
3. Evidence of UKCA marking in accordance with UK Construction Production Regulation.
4. Details of external window and door fixing will be required.
5. Details of sealing around the frame will need to be confirmed.
6. Details relating to the quality control processes for the procurement of metals, and the quality control processes of the factory where they are assembled.

The Warranty surveyor, at their discretion, may also request supporting information that demonstrates suitability for use of any materials or systems contained within the above.

Certification

External aluminium/steel windows and doors shall have evidence of certification confirming weather-tightness rating as detailed within BS 6375.

The design and construction of factory assembled external windows and doors must meet BS 4873 for aluminium windows and door frames and BS 6510 for steel window and door frames.

Non factory assembled units and 'bespoke' units are also expected to meet the same standards.

Fixings of external aluminium & steel window & doorsets

Frames should be fixed in accordance with the manufacturers recommendations or, if no instructions are given, in line with the following guidance.

Fixing locations for external aluminium windows and doorsets

All sides of the frame should be secured as follows:

*Additional fixing for windows & doorsets over 1800mm wide

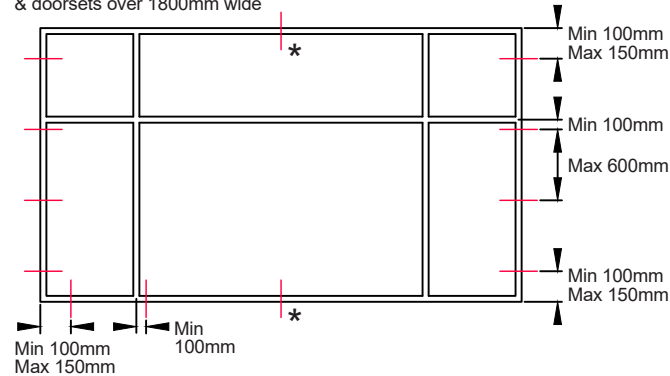

- Corner jamb fixings should be between 100 mm and 150 mm from the external corner.
- Fixings should be a minimum of 100mm from the centre line of a mullion or transom.
- Intermediate fixings should be at centres no greater than 600 mm.
- There should be a minimum of two fixings on each jamb.
- On windows and doorsets over 1800 mm wide, central head and sill fixings should be provided 100mm or more distant from any mullion that might coincide.

Fixing locations for external steel windows and doorsets

All sides of the frame should be secured as follows:

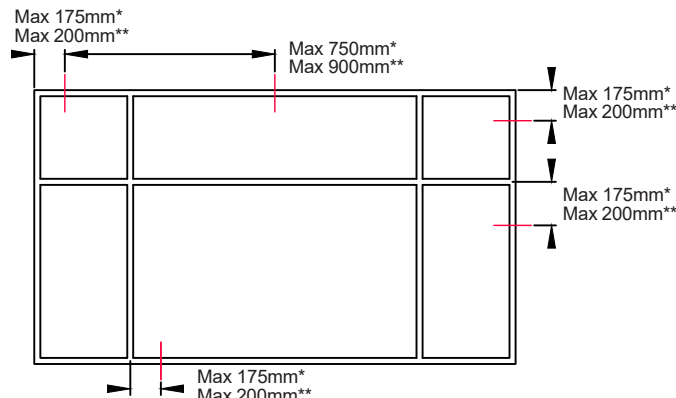

- * Dimension for hot rolled sections
- ** Dimension for cold rolled sections

For steel frames of hot rolled solid section

- Fixings should be a maximum of 175 mm from corners.
- Intermediate fixings should be at centres no greater than 750 mm.
- For steel frames of cold formed hollow section:
- Fixings should be a maximum of 200 mm from corners;
- Intermediate fixings should be at centres no greater than 900 mm.
- Either into pre-tapped holes with machine screws a minimum of 5mm diameter or with power driven hardened self-drilling screws.

Fixing type

- Two methods of fixing are lug fixing, or through frame fixing. These can be used separately or as a combination.
- Should be galvanised steel cramps or by non-corrodible screw fixings appropriate to the surrounding wall.

Fixing substrate penetration

Fixings should penetrate surrounding structure in line with the relevant section below.

Into masonry, by at least:

- 40mm for external windows.
- 50mm for external doors.

Into structural timber framing, by at least:

- 25mm for all situations.

For fixings into surrounding structure formed by steelwork which is a maximum of 2mm thick should be made with:

- Power driven hardened self-drilling screws or self-tapping screws (with pilot hole).

For fixings into surrounding structure formed by steelwork which is greater than 2mm thick should be made:

- Either into pre-tapped holes with machine screws a minimum of 5mm diameter or with power driven hardened self-drilling screws.

Note: Fixings should not be made into the insulated cavity closer.

Gaps around external windows and doors

Gaps around external windows and doors should be sized to allow for thermal movement and this will vary depending on the material of the frame.

Material	Recommended gap per side for width of structural openings (mm)		
	Less than 1.5m*	1.5m – 3.0m*	3.0 – 4.5m**
Steel	4	5	6
Aluminium	5	5	7.5

Notes:

* The maximum gap permitted for openings less than 3m should be 10mm.

** For openings more than 3m, the maximum gap permitted should be 15mm.

For gaps greater than 5mm, a backing strip should be provided behind the sealant and the sealant should have a minimum depth of 6mm.

External window and door frames should be installed in accordance with the manufacturer's instructions.

Additional provisions of information for powder coated aluminium:

- Present details of quality management system from recognised source (such as ISO 9001).
- Provide details confirming that the operations will be completed in line with BS EN 12206-1.
- Provide details of pre-treatment to frames.
- Provide details of the powder coating manufacturer and confirmation that the applicator is an approved installer with regular, up-to-date audit records.
- Provide details of third party guarantees (e.g. adhesion, colour, etc).
- Provide details of third party accreditations (such as QUALICOAT, etc.).
- Provide full specification details for the application, outlining why the proposed product is best suited for use.
- Provide details of necessary future maintenance.

Aluminium frames to receive powder coating must be pre-treated to ensure good adhesion of the coating to the surface. Pre-treatment seals the surface of the aluminium and helps form a "key" for the powder coating to adhere to. It is necessary to remove all forms of contamination, the naturally forming oxide layer, and any deformation layer prior to applying the powder coating.

Pre-treatment of aluminium frames should not include the use of hexavalent chromium. The pre-treatment of components to be powder coated is covered within BS EN 12206-1.

Durability

For external window and door frames in coastal locations the durability of the coating must take into account of aggressive environment conditions. Please refer to 'Appendix B' for further guidance.

Standards

Design, specification, and manufacturing

- BS 4873 Aluminium alloy windows and door sets.
- BS 6510 Steel windows and doors.
- BS 6375 Performance of windows and doors - Classification for weathertightness and guidance on selection and specification.
- Air permeability - BS EN 12207 - Classification & BS EN 1026 - Test method.
- Water resistance - BS EN 12208 - Classification & BS EN 1027 - Test method.
- Wind resistance - BS EN 12210 - Classification & BS EN 12211 - Test method.
- BS EN 1670 Building hardware. Corrosion resistance. Requirements and test methods.

Installation

- BS 8213 Windows and doors - Code of practice for the survey and installation of windows and external doorsets.

8.

External Windows and Doors

8.5 Additional Requirements for Vertically Stacked Coupled Window Assemblies

Provision of information

A full set of design drawings and specifications shall be made available to the Warranty Provider and all other interested parties prior to the associated works starting on site. This may include:

1. A fully specified system for the coupled window assembly and this must include details of dual sealed coupling joints, seals, fixings and other ancillary components.
2. Evidence of CE/UKCA marking in accordance with UK Construction Production Regulation.
3. Details of proposed testing strategy as outlined within CWCT Note 41 and 102 are to be provided along with test report.
4. Evidence of certification confirming weather-tightness rating as detailed within BS 6375-1.

The Warranty surveyor, at their discretion, may also request supporting information that demonstrates suitability for use of any materials or systems contained within the above.

Introduction

Vertically stacked coupled window assemblies for the purposes of Warranty, are more than one separate glazed panel and frame unit coupled together vertically in an external wall elevation.

The guidance within this section is limited to where coupled window assemblies are:

- Specified in low rise construction (Buildings of 5 storey or lower – including the ground floor level); and,
- Coupled in a vertical position.

The guidance within this section should be read in conjunction with the rest of the applicable guidance in the 'External Windows and Doors' section.

Typical detail

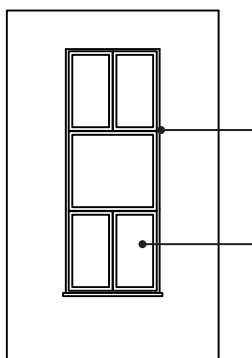

All junctions will require to be weather tested, see associated guidance on this page.

The lower unit must be able to support the upper unit structurally subject to an engineer's design.

Fixing should allow for differential movement if in a timber framed building as well as suitability to join one frame to the other. Fixings must also meet the requirements of BS8213: 4 for spacing requirements with particular emphasis on the side and tops.

General requirements

Vertically stacked coupled window assemblies must be part of a fully specified system and this must include details of dual sealed coupling joints, seals, fixings and other ancillary components.

Vertically stacked coupled window assemblies must be manufactured to BS

7412, BS 4873 or BS 6510. Timber coupled window and door assemblies are not acceptable for Warranty purposes.

Where vertically stacked coupled window assemblies are proposed, thermal breaks should be incorporated into the dual sealed coupling joints.

Vertically stacked coupled window assemblies need to be sealed at the edges and drained at the front to prevent water ingress at the edges.

Testing

Where vertically stacked coupled window assemblies are proposed, they will require both off-site and on-site testing as detailed below.

Off-site testing

Vertically stacked coupled window assemblies require off-site testing to BS EN 14351-1 and this must be for the complete coupled window assembly (with the dual sealed coupling joint in place), not just individual units.

Vertically stacked coupled window assemblies with higher levels of performance will be required for locations exposed to high levels of driving rain and this should be detailed by the system manufacturer.

Please note: individual units with third party certification may not cover a coupled window assembly scenario.

On-site testing

Where vertically stacked coupled window assemblies are proposed, on-site testing of water penetrations to critical joints (such as dual sealed coupling joints) in accordance with CWCT test methods is required to check to site workmanship of the building envelope as constructed. Areas and method of testing is to be agreed with the Warranty Surveyor prior to construction commencing. See CWCT Technical Note 41 and 102 for guidance.

Minimum requirements for on-site testing may be increased for areas subject to extreme weather conditions, exposed locations or coastal locations. The testing may also be increased where bespoke jointing systems are proposed as part of the construction.

Dual sealed coupling joints

Where vertically stacked coupled window assemblies are specified, pre-fabricated dual sealed coupling joints should be used for creating a weathertight joint. A dual sealed coupling joints should include:

- Outer seals as the primary water barrier.
- Inner seals providing an air barrier and secondary water barriers. The air barrier must be fully continuous around the full perimeter of the window.
- A drained cavity to remove any water that passes the outer seal. This should be detailed to prevent water entering parts of the structure which are not intended to becoming wet.

Inner seals within the coupling joint must be placed within the joint during the assembly operation and be suitable for the proposed detailing. Suitable inner seals include impregnated foam tapes or flexible polymer gaskets. Wet sealants should not be solely relied upon.

If sealants (internal or external) are inaccessible or not easy to replace, their service life should match the service life of the window system as a minimum.

All seals must be permanently flexible and resistant to weathering.

All external sealants must be easy to replace.

Structural integrity

Vertically stacked coupled window assemblies must be designed to be able to appropriately transfer its self-weight and imposed loads to the supporting structure.

The frame of the window needs to be able to resist the wind load in deflection, alternatively, the joining component needs to provide support and contribute to the overall stiffness of the system in resisting deflection.

Where the vertically stacked coupled window assembly extends to more than one window in both directions, the joining component in one direction must span the full width or height of the assembly and will have to carry all the load at the junction(s) between the window frames. It will also have to support the ends of the joining components running in the transverse direction.

Window sill

Vertically stacked coupled window assemblies must incorporate a sill which projects from the wall by at least 25mm. The water drip must project the wall by at least 10mm.

Vertically stacked coupled window assemblies may encounter an extra volume of rainfall due to the increase in the amount of glazing used in the window system. This should be taken into account with the window system to ensure rainfall is discharged away from the building and does not impact on the weatherproof envelope.

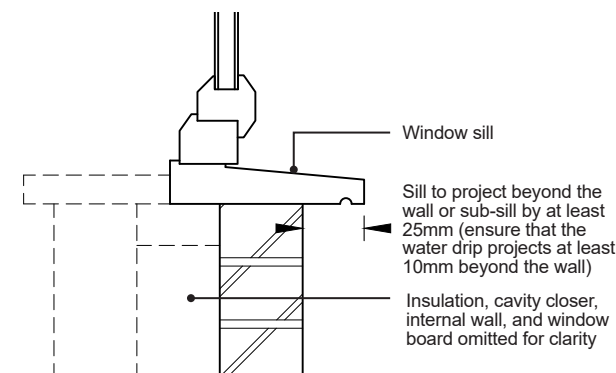

Accommodating movement

Gaps are required around external windows and doors to accommodate differences in movement between the window and the surrounding wall construction as specified in our 'External Windows and Doors – General requirements' section.

Where vertically stacked coupled window assemblies are specified however, the gap sizes between the frame and wall construction may need to be greater and this should be specified by the system manufacturer.

Where a vertically stacked coupled window assembly extends across a horizontal movement joint (in a timber framed building with lightweight cladding for example), the design should allow for suitable jointing of the window assembly that will accommodate predicted structural movement whilst remaining weathertight and transferring loads to the building structure.

Vertically stacked coupled window assembly over 5 storeys

While the guidance within this section is predominantly for low rise developments, it should be noted for developments of 5 storeys or over, developers and designers should consult with our Major Projects team for further advice. For testing the following will be required:

- A minimum performance of 600 pascals water tightness will need to be achieved for vertically stacked coupled window and door assemblies
- Vertically stacked coupled window assemblies will need to comply with CWCT Technical Note 95.

8.

External Windows and Doors

8.6 External Bi-fold Doors

Provision of information

A full set of design drawings and specifications shall be made available to the Warranty Provider and all other interested parties prior to the associated works starting on site. This may include:

1. A full specification of the external bi-fold door must be provided to the Warranty Surveyor.
2. The designer must take thermal bridging into account. Details of how thermal bridging is to be mitigated must be provided to the Warranty Surveyor
3. Where external top hung bi-fold doors are specified, the Engineer must design and specify the lintel provision above the bi-fold doors.
4. The provision of information in the other sub-sections within the 'External Windows and Doors' section must also be satisfied.

The Warranty Surveyor, at their discretion, may also request supporting information that demonstrates suitability for use of any materials or systems contained within the above.

General

Where external bi-fold doors are specified, the guidance within this sub-section must be read in conjunction with the guidance within the rest of the 'External Windows and Doors' section.

The designer must take thermal bridging into account. Details of how thermal bridging is to be mitigated must be provided to the Warranty Surveyor.

Installation

Where external bi-fold doors are specified, the manufacturer's guidance must be followed to ensure structural stability, weather resistance and desired service life is achieved.

Where external top hung bi-fold doors are specified, an Engineer must design and specify the lintel provision above the external bi-fold doors.

Level access thresholds

Care must be taken for level access threshold detailing to ensure weather resistance is maintained. Falls in the external ground levels must be away from the building.

The sill must project a minimum 25mm (ensure the water drip projects at least 10mm beyond wall) into a channel drain which is laid to a 1/60 fall. Please refer to the 'External Windows and Doors – General Requirements' section for further guidance.



2 Shore Lines Building, Shore Road, Birkenhead, Wirral, CH41 1AU
T 0800 107 8446 | E info@premierguarantee.co.uk | [premierguarantee.com](https://www.premierguarantee.com)

Technical Manual V16 - TS-011-16.00-010424 © Premier Guarantee 2024

MD Insurance Services Ltd is the Scheme Administrator for the Premier Guarantee range of structural warranties. MD Insurance Services Ltd is authorised and regulated by the Financial Conduct Authority.

